

EBBS Product Manual



Copyright© 2025 EarthX, Inc. All rights reserved. The information contained in this document is the property of EarthX, Inc. EarthX reserves the right to make changes to its documents or products without notice. It is the responsibility of each user to ensure that all applications of EarthX's products are as intended and safe based on conditions anticipated or encountered during use. The EarthX logo is a trademark of EarthX,

Revision Log

Rev	Description	Date	Approved By:
New	Created New	11/12/2025	Nicoson
A	Updated for Pin5	2/15/2026	Nicoson

Table of Contents

Revision Log	2
Overview	4
Description	4
Battery Cells	4
BMS	4
Backup Power	5
Specification	5
Cable Pin-out	5
Installation Requirements	6
Installation and Replacement Instructions	7
Product Mounting	8
Wiring Diagrams	10
Inspection	11
Battery Inspection Intervals	11
Battery Inspection Instructions	11
Operating Instructions	13
Start-up Procedure	13
Shut-down Procedure	13
Emergency Procedure for loss of main aircraft electrical power....	13
Maintenance	13
Battery Charging	13
Troubleshooting	14
Storage and Handling	15
Weight and Balance	16
Warranty	16
Regulations and Standards	16

ICON KEY

 Valuable information

 Caution

 Warning

Overview

The EarthX Battery Backup System (EBBS) is engineered specifically for avionics and critical aircraft electrical systems. The EBBS can be used as a secondary power source for equipment with a second power source input or as an uninterruptable power source (aircraft power pass-thru with battery backup) for equipment with a single power input.

It can be used to power:

- Electronic Flight Instrumentation Systems (EFIS)
- GPS
- Engine Monitors
- Transponders
- Electronic Ignition



Failure to follow all application use, installation, charging, and storage instructions may result in battery damage and or thermal runaway! Never disassemble the battery or disable the built-in Battery Management System (BMS) under any circumstance.

Description

Battery Cells

The EBBS uses cells made of Lithium Iron Phosphate (LiFePO₄). This chemistry has superior performance and exceptional safety, the safest on the market today.

A lithium batteries voltage remains relatively constant while discharging, as such, a lithium battery as a backup power source will deliver all its energy with the voltage remaining above 10.5 volts.

LiFePO₄ cells by the nature of their chemistry are 3.3 volt. Another difference is that lithium cells are dry cell technology, where the cells are packaged individually. Individual cell's charge level will diverge with repeated charge/discharge cycles and age. This condition reduces the performance of the battery (reduces capacity) without a Battery Management System (BMS) to monitor, control and protect the cells.

BMS

EarthX's integrated Battery Management System (BMS) continuously monitors bus voltage, cell voltage, pack voltage, current, and temperature to provide the following protective functions:

- **Over-charging (over-voltage):** The charge current is blocked above 15 volt; auto-reset when bus returns to < 15 volts. The discharge current (current out of battery) is unaffected in this situation.
- **Over-discharge:** If the battery cells are damaged as a result of severely over-discharging, the battery will not allow re-charging. The discharge current (current out of battery) is unaffected in this situation.
- **Short-circuit/over-current:** The current out of the battery is interrupted in the case of direct short or current demand > 14 amps; the internal breaker automatic resets after the fault is removed and device cools.
- **High Temperature:** Charging is halted above 85DegC.
- **Cell Charge Level Imbalance:** Internal circuitry works to equalize the charge level of the cells.

EBBS BACKUP BATTERY

- **Fault / Status:** The fault LED output is active (active low level) when any of the following is true; high temperature (>75 DegC), < 50% State of Charge (SoC), cell to cell charge level imbalance.

The BMS was designed to Design Assurance Level (DAL), C (major).

Backup Power

The EBBS connects to the aircraft electrical bus and provides output power to critical equipment that requires two power sources or a redundant power source. The EBBS acts as an un-interruptible power source by passing aircraft electrical bus power thru the device when the bus voltage is within a normal range (11.5 – 15 volt), but switches to the internal battery power when the bus voltage drops below 11.5 volts or goes above 15 volt.

An additional benefit of the EBBS is voltage sag protection, allowing operation of critical equipment during engine starting.

Specification

Operating Voltage	10-15Vdc
Aircraft Bus Voltage to allow Charging	12-14.5Vdc
Voltage to Transfer to Backup (internal battery)	<11.5 Vdc
Pass-thru Current	8 A
Output Current	8 A continuous; 12 A peak (≤ 30 s)
Battery Chemistry	LiFePo4
Charge Current	3 Amps
Weight	2.4 lbs./1 Kg
Dimensions	151mm X 76 mm X 84mm (LxWxH)
Operating Temperature Range	-30 deg C to 65 Deg C
Connector	15 Pin Male Connector

Cable Pin-out

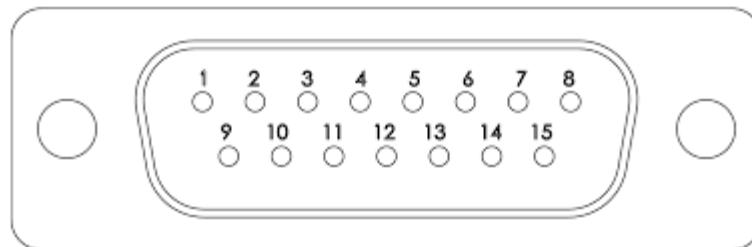

15-Pin Male Type D-sub-Connector

EBBS BACKUP BATTERY

Pin Number	Description	I/O
1	Enable Backup Master Switch	Input
2	EBBS Battery Voltage Monitor (for display on EFIS)	Output
3	EBBS External LED Output	Output
4	EBBS Power Output	Output
5	Bus Power Input for Charging	Input
6	Bus Power Input (for pass-thru)	Input
7	Bus Power Input (for pass-thru)	Input
8	Bus Power Input (for pass-thru)	Input
9	Aircraft Ground	-
10	Aircraft Ground	-
11	Aircraft Ground	-
12	EBBS Power Output	Output
13	EBBS Power Output	Output
14	EBBS Power Output	Output
15	EBBS Power Output	Output

Pin 1: Enable Backup Master Switch; this switch is connected to ground to enable (turn on) the backup battery function (the internal battery powering the power output pins). The power pass-through is unaffected by this switch. This switch also gives the pilot the ability to turn the back-up battery system off.

Pin 2: Battery Voltage Monitor; this output can be wired to an analog input of an EFIS to monitor the EBBS's internal battery voltage. This pin will only output voltage when the unit is enabled by turning the Back-up Master switch ON. Only connect this output to a high-impedance inputs ($\geq 100\text{ k}\Omega$). Low-impedance meters will read artificially low.

Pin 3: LED Output; this output is used turn on a 12-volt LED to signal low bus voltage and that the EBBS is supplying power to the loads (steady on). When the charge level of the EBBS's internal battery has dropped below 50%, the output will be cycling on / off slowly (5 second on/ 5 second off). This output is connected to battery ground when a fault is present. This output pin is connected to the negative side of the LED. There is a 30 second delay to turn off the LED. The maximum current that can be sourced from this pin is 25mA. If this pin is connected to an EFIS contact input, a pullup resistor may be required.

Pin 4, 12-15: Power Outputs; these are the output power connections for the EBBS. These pins are connected to the aircraft electrical loads. When the bus voltage on this pin fall below 11.5 volts the EBBS automatically transfers the load to the internal battery. The maximum allowed current per pin is 3 amps. For example, if the load is 8 amp, 3 pins are required. Use 20AWG wire for each pin. These outputs are protected by an internal 12amp auto-resetting fuse. To reset the fuse, disconnect the loads for 30 seconds.

Pin 5: Power Input; this pin should be connected to the aircraft main electrical bus. It is used to sense bus voltage and charge the EBBS battery only.

Pin 6-8: Power Inputs for Pass-thru; these pins should be connected to the aircraft main electrical bus for power passthrough. Power if available, is passed through (through a diode) to the power output pins 4 and 12-15. The pins are internally wired in parallel.

Pin 9-11: Aircraft Ground; these pins should be directly connected to the aircraft ground. The pins are internally wired in parallel.

Installation Requirements

The following are the installation requirements:

EBBS BACKUP BATTERY

- The EBBS is **not** approved for engine cranking, starter-motor loads, or as a primary battery in any application.
- Automatic over-voltage protection is required on the aircraft charging system. Do not install battery if the aircraft does NOT have over-voltage protection.
- Adhere to the environmental and electrical limits (see Specification section of this manual).
- Do not use a single EBBS to power more than one electronic ignition module. Follow the electronic ignition manufacture instructions.
- When used to power electronic ignition systems in addition to other devices, the other loads must have over-current protection (rated 3 amp or less)
- Do not parallel multiple EBBS units.

Installation and Replacement Instructions

It is recommended you check the EBBS voltage before installing. If the voltage is below 13.2V, charge the battery before installing. Installations should also follow AC 43.13-1B/2B practices and the aircraft equipment manufacturer's instructions.

Preplanning

Plan your power connections, typically one power output to a single device. If your device has a backup power input (like a Garmin G3X), the EBBS power output must be connected to the "back-up" power input. For equipment with a single source of power, the EBBS's power output is connected to that single input (with the EBBS providing the redundancy).

Protect the EBBS input power with a dedicated fuse/breaker sized for the charging current and pass-through current.

ENSURE the proper size wire is utilized for the power inputs and outputs and ground (20ga is typical for the DB-15 connector). Use aircraft-grade wire; size per continuous output plus run length; ground returns to aircraft ground. Route harnesses to avoid chafe/heat; strain-relief the D-sub; observe minimum bend radius; keep harness separated from high-current cables.

Do not connect the EBBS to inductive loads (starter, flaps motors, pumps) unless separately fused and within rated output specification (up to 3 amps per power output pin).

Follow these steps to install the EBBS initially:

1. Check that the total connected load is less than EBBS's specifications.
2. Mount the EBBS in a suitable location in the aircraft using (4) #8 screws (see mounting figures below). Select an area that is accessible and within the operating temperature range (see the Specifications section of this manual).
3. Connect the power output wires from an EarthX cable (part # EBBS-CABLE) or other compatible cable to the aircraft loads (reference the wiring diagram below).
4. Connect the power input wires from an EarthX cable (part # EBB or other compatible cable to the aircraft electrical bus power source through a properly sized breaker.
5. Connect the enable backup input (pin 1) to a suitable switch.
6. If equipped, connect the battery voltage (pin 2) to an EFIS analog input (reference the wiring diagram below).

EBBS BACKUP BATTERY

7. Connect the LED output (pin 3) to a suitable panel mounted LED or EFIS discrete input (fault on low level).
8. When wiring is complete and verified, attach the connector to the EBBS.

Return to service checks:

1. Verify the equipment operation, powered by the EBBS. Check that the connected load operates for the desired duration, but not less than 35 minutes.
2. At the EBBS, jumper the fault/status (pin 3) output to aircraft ground and verify panel LED/EFIS fault indicator is “On”.

Follow these steps to replace the EBBS:

1. Unplug the connector from the EBBS.
2. Remove the (4) #8 mounting screws, and remove the unit.
3. Mount the replacement EBBS using (4) #8 screws.
4. Re-attach the connector to the EBBS.



Remove all metal objects from your person before handling the battery and use insulated tools for installation. Avoid touching or probing connector pins.

Product Mounting

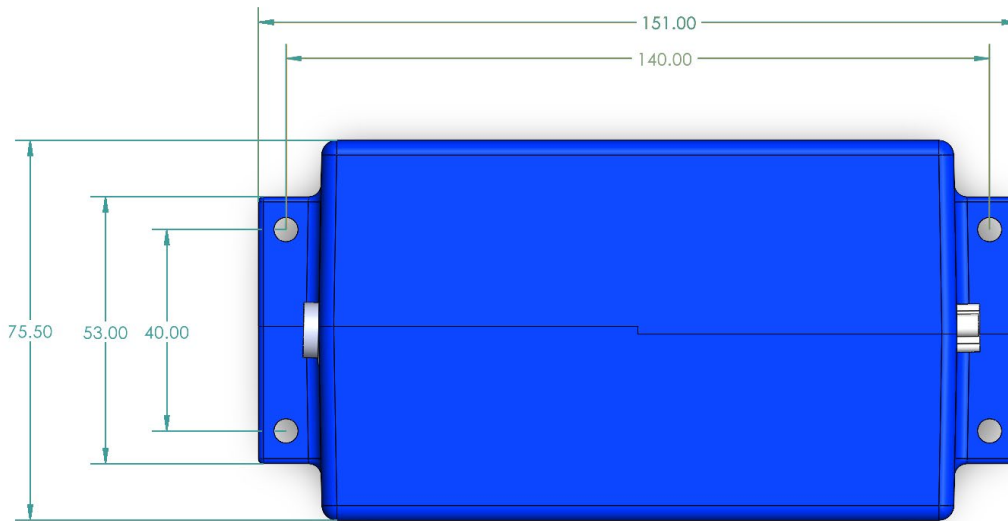

EBBS (Top View)

EBBS BACKUP BATTERY

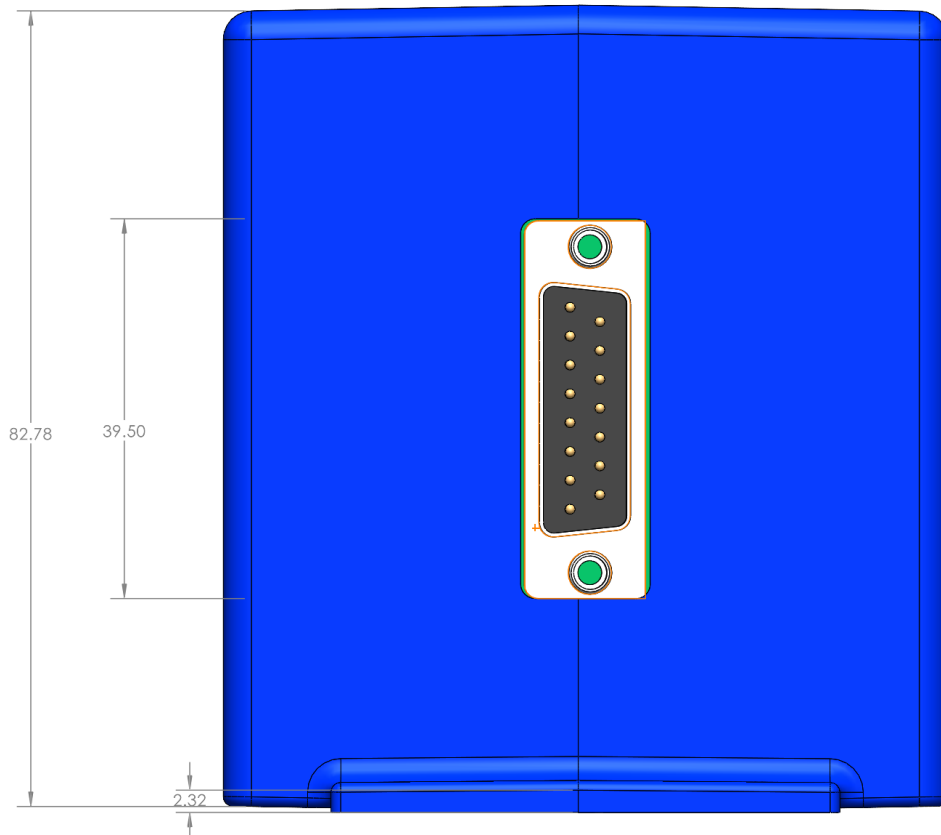

EBBS (End View)

EBBS BACKUP BATTERY

Wiring Diagrams

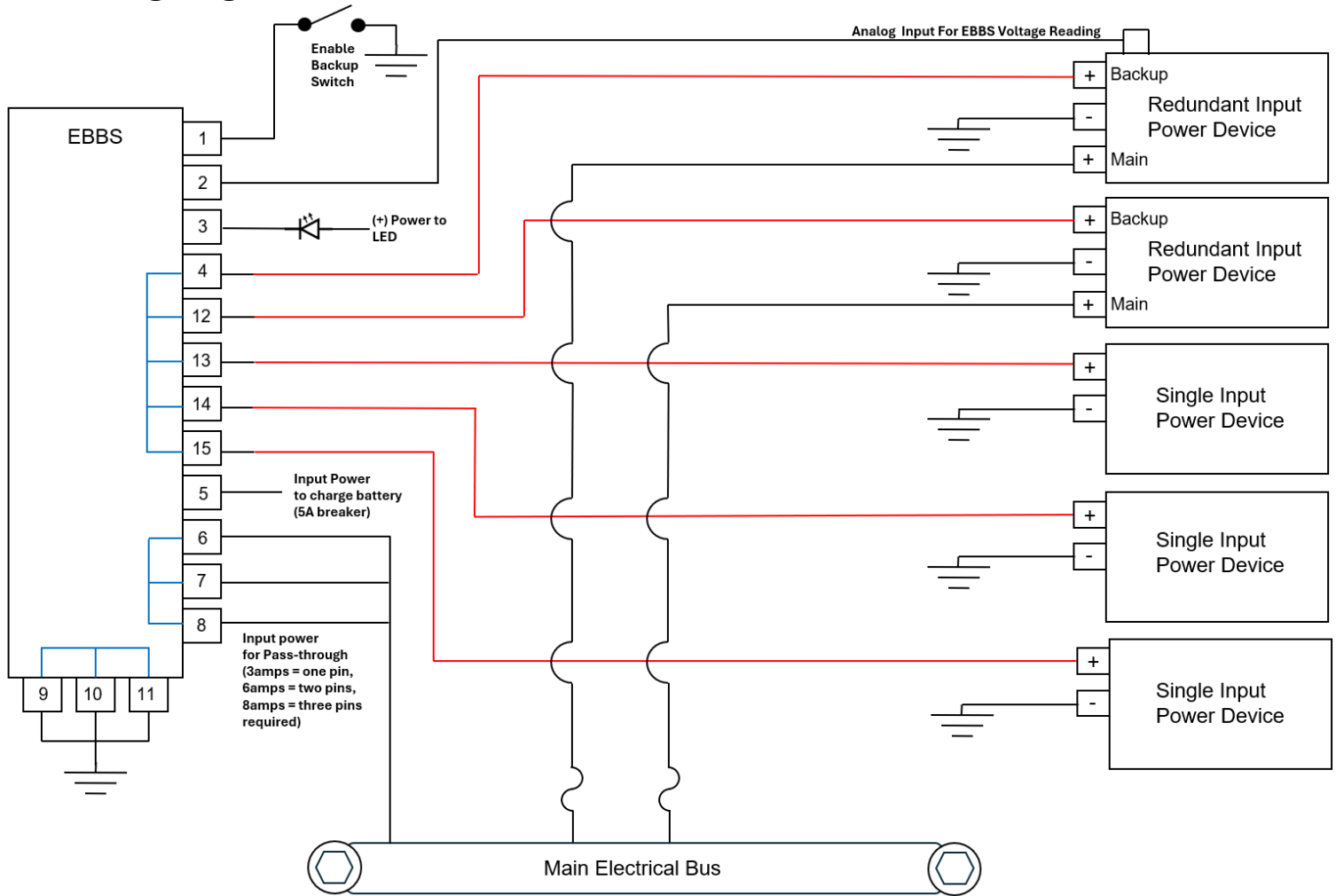

Example Wiring Configuration

EBBS BACKUP BATTERY

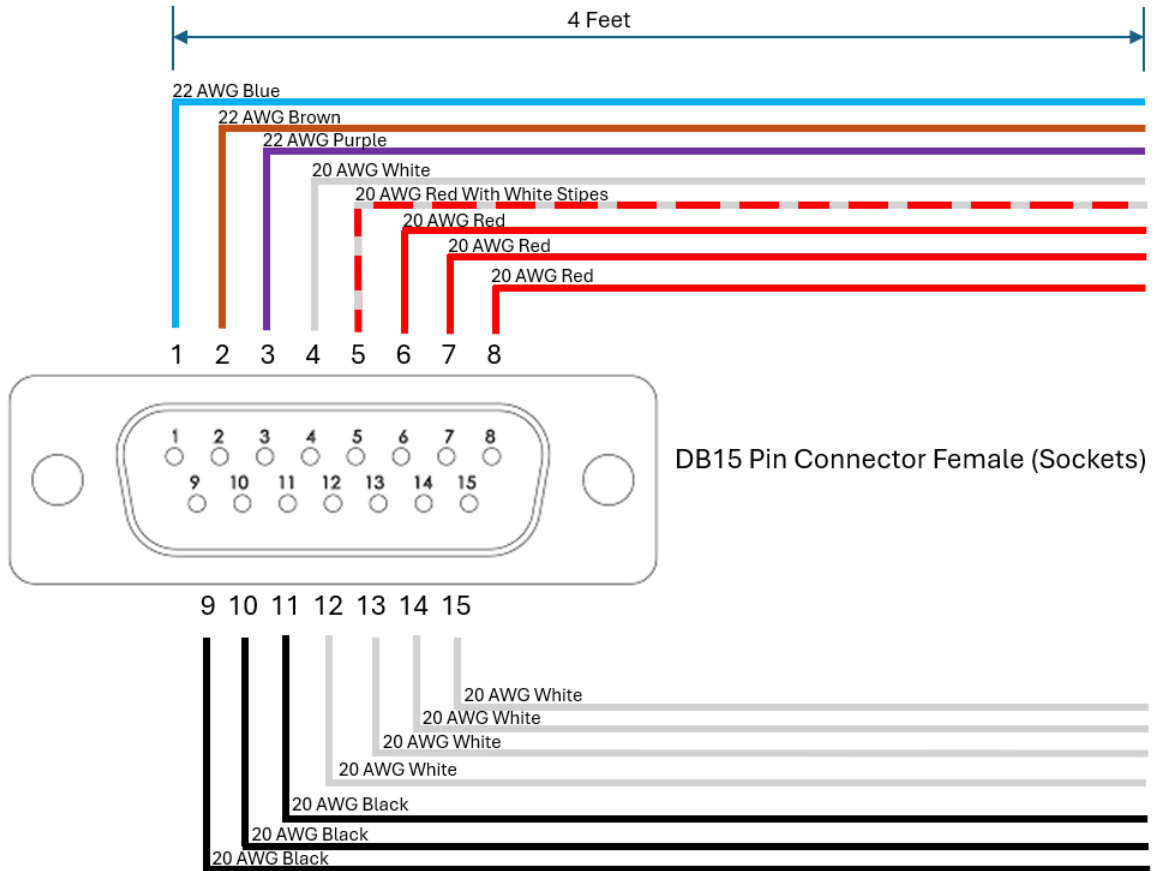

EarthX Cable (part # EBBS-CABLE)

Inspection

This is a non-certified battery, so the following is only recommended. The supplemental Instructions for Continued Airworthiness (ICA) are required by 14 CFR part 23 for this Article (Part) installed on Aircraft (14 CFR 23.1529 for this application and TSO).

Battery Inspection Intervals

Upon installation, record the next battery inspection due date based on the battery age as follows:

- 0-24 months: The battery must be inspected on or before the date the battery turns 24 months old.
- 24+ Months: If the battery was inspected at Annual Inspection, the due date for the next inspection is at the next annual inspection. If the battery was inspected at a time other than annual inspection, inspect the battery no later than 12 months after the last inspection date.

Battery Inspection Instructions

The following inspections/tests shall be performed:

- 1) Visually inspect the battery for signs of damage; plastic case cracks, warped plastic or long side of the battery is swollen. Replace if damaged.

EBBS BACKUP BATTERY

- 2) Verify the battery fault/status monitoring LED is operational. To do this, use a wire jumper to connect the fault/status discrete output (which connects to the fault output pin) to battery ground, and verify the LED is lit.
- 3) Ensure the battery is fully charged.
- 4) After fully charging the battery in the previous step, allow the battery to rest overnight (minimum of 12 hours) without any load applied to the battery. Verify the battery is “holding a charge” by confirming the voltage is greater than 13.3 volts.
- 5) Verify the battery capacity. A battery’s current capacity as compared to its original capacity is an indication of the battery’s remaining service life. A battery with greater than 80% of its original “rated” capacity is considered fit for continued service. If the battery capacity is less than 80%, then it must be replaced. Alternately, if the battery capacity can support the aircraft’s emergency load for the required amount of time it is considered fit for continued service. It is recommended that the battery be replaced after 6 years of service. To test the battery capacity with a battery load tester:
 - a. Fully charge the battery
 - b. Connect the battery to a constant current load tester.
 - c. Set the tester’s current setting to a 1C rate (i.e. 7.8 amps)
 - d. Begin discharging and start a timer.
 - e. End the test when 48 minutes has expired or voltage drops to below the cutoff voltage (111 volts). If the battery delivers power for 48 minutes with voltage above 11 volts, it passes.
 - f. Fully charge the battery.

Alternately, if no battery tester is available:

- a. Fully charge the battery
- b. Turn on all electrical loads for flight operation and start a timer.
- c. Measure and record the battery’s discharge amps using a DC clamp-on current meter at the positive terminal of the battery.
- d. Using the measured amps in the previous step and the battery’s nameplate rated capacity (in Ah), calculate the time to discharge the battery 80%.

$$\text{Time to discharge 80\% (Hours)} = \frac{\text{Rated Capacity in Ah} * .8}{\text{Measured Discharge Amps}}$$

For Example, (11.7 Ah Rated Capacity, 8 amp measured discharge rate)

$$\text{Time to discharge 80\%} = \frac{11.7 * .8}{8} = 1.17 \text{ hours}$$

- e. Terminate the test after the number of hours calculated in the previous step has expired or if the battery is over-discharged (shuts off discharge current). If the battery is still supplying power at the termination of the test, then the battery’s capacity is greater than 80%. If the battery’s capacity is greater than 80%, then the battery has passed the test.
- f. Fully charge the battery.
- 6) Inspect battery cable /wires for wear, and loose terminal connectors.
- 7) Record inspection results in the Aircraft Logbook(s).

Operating Instructions

Start-up Procedure

1. Enable Backup Switch – ON.
2. Turn on any equipment powered by the EBBS and verify the equipment operates properly.
3. Aircraft Master Switch– ON; verifying the connected equipment remains powered on.
4. Verify EFIS (if equipped) reads a normal EBBS voltage (12.8 – 14.5 volts).
5. Verify no fault indication (LED off / EFIS alert off).

Note: if load exceeds the output amperage rating, the internal fuses will open. To reset the fuse, turn off the “Master Backup Enable” switch or remove the load for 30 seconds (fuse resets automatically).

Shut-down Procedure

1. Master – OFF; verify connected equipment remains powered on.
2. Enable Backup Switch – OFF; verify connected equipment powers off.

Emergency Procedure for loss of main aircraft electrical power

Ensure the Enable Backup Switch is on (Enable). The EBBS automatically maintains power to its connected devices. No pilot action is required. Continue to monitor the EBBS fault / status LED and voltage (if connected to an EFIS).

Land aircraft as soon as practicable.

Maintenance

This is a maintenance free battery with no internal replaceable components. Charging is only required as needed.

The following conditions indicate battery end-of-life, and the battery shall be replaced:

- Insufficient capacity per inspection requirements above
- On-going battery fault indication (refer to the “Troubleshooting” section)
- Will not hold a charge (<13.2 volts a week after charging the battery to full charge)



At battery end-of-life contact EarthX. The only approved replacement lithium battery is an EarthX battery of the same model number. The model number is displayed on the top label of the battery.

Battery Charging

If at any time the battery seems low, or the voltage is less than 13.2 volts, charge it. To charge the battery, connect the battery charger to the battery 15 pin connector and leave the charger “On” until the charge light is extinguished.

EBBS BACKUP BATTERY

This table shows typical charging times using the EarthX charger (part # EBBS-CHG-12).

Charging Amps	Charging Time
2 amp	4 hours

Lithium batteries have a very low self-discharge rate which means the battery, if disconnected from the aircraft (Enable Backup Switch off), could “hold its charge” for over a year, but we recommend charging every 6 months if not in use.

If the battery has been over-discharged, the voltage of the internal battery is < 8 volt, connect the approved EarthX charger for 20 minutes, then recheck the voltage. If the voltage is > 13, and the battery is holding a charge (voltage does not decrease over 20-minute period), the battery is ok to fully charge. If charging does not complete or the battery does not hold a charge contact EarthX technical support.



Never charge a faulty battery (a battery that will not accept a charge or hold a charge).



If the battery gets hot while charging, discontinue charging and use.



Do not charge battery in temperatures above 140 degrees F (60C), or in direct sunlight.



When charging a battery outside the aircraft, place it on a non-flammable surface, and remove any flammable items nearby.

Troubleshooting

The EBBS is an integral part of the aircraft electrical system and as such to is useful to know the aircraft electrical system voltage at the time of the battery fault.

The Voltage/Current column in the table below lists the voltage/current level or condition that could correspond with the battery fault. For example, over-voltage is an electrical system problem and may be reported and addressed with other aircraft equipment.

The table below is a summary of the battery’s fault/status codes (discrete output).

LED Light	Voltage	Possible Cause	Recommended Action
Solid Light	Less than 12.7V	Battery over-discharged due to faulty charging system (alternator) not charging the battery.	Charge the battery with the EarthX supplied charger. Verify aircraft charging system is functioning.

EBBS BACKUP BATTERY

Solid Light	12.5-14.5V	Weak or failing cell	Charge the battery with an approved charger and observe fault LED. If LED persists (another flight), charge the battery a second time. If the LED fault persists, for several consecutive flights, the battery should be replaced.
Solid Light	Greater than 15V	Over-charging (due to faulty charging system regulator)	Verify aircraft charging system is functioning properly; could be faulty voltage regulator and or over-voltage protection device.
Solid Light	Any voltage	BMS electronics issue	Isolate the battery from the aircraft (disconnect cable). If the fault is not extinguished, the battery should be replaced.
Off; but no output power (reset automatically)	Any voltage	Short Circuit protection was activated	Turn off the “Master Backup Enable” switch or remove load for 30 seconds, internal fuse resets automatically. Verify loads connected to the battery are within the specification.
Solid Light	Any voltage	Battery temperature very high (> 85°C / 185°F); warn to the touch.	Let the battery cool down prior to charging. Re-locate the battery to a cooler environment.

Table 3 Battery Fault / Status Codes

For additional information go to <https://earthxbatteries.com/> and review the FAQs.

Storage and Handling

Upon receiving the battery check it for any physical damage, such as cracks, or a swollen case.

If storing the battery, it can be stored at temperatures between -40°C to +70°C. The recommended storage temperature is -10°C to 40°C. Our batteries have no liquid inside and will not freeze. Keep batteries in their original packaging or use appropriate containers to prevent short circuit of the terminals and physical damage.

If the aircraft is to be put in storage for an extended period (> 6 months), ensure the battery is fully charged. A fully charged battery can be put in storage for up to a year without charging but should be charged and inspected annually.

Special care must be taken in the handling, shipping, and storage of rechargeable lithium batteries. As a result, installers, end users, and personnel involved in the maintenance and disposal of rechargeable lithium batteries require training in the special characteristics related to rechargeable lithium battery safety. Leaving

EBBS BACKUP BATTERY

battery output terminals or leads exposed may result in external short-circuiting of the battery during shipping, handling, testing and installation.

Batteries can be recycled at any location accepting lithium-ion type batteries. Drain battery and or cover terminals with electrical insulating tape prior to recycling. For recycling information and where to recycle check this website (<https://www.call2recycle.org/>).



Do not incinerate or expose to open flames!



The Safety Data Sheet (SDS) is available on EarthX's website.



Always follow the manufacturers' recommended safety precautions and procedures.

Weight and Balance

The installation of the EBBS battery is considered a permanent installation. The basic aircraft weight and balance should be updated inclusive of the added equipment when the installation is completed and documented on the aircraft Weight and Balance Record (WBR). The battery weighs 2.4 pounds.

Warranty

EarthX, Inc. (Manufacturer) warrants its lithium batteries (hereafter referred to as Battery or Batteries) to be free of defects in material and workmanship for a period of two years. A dealer is not authorized to issue a replacement battery without prior authorization from EarthX, Inc.

The applicable Warranty period begins from the date of purchase on the original receipt, or, if no receipt is available, from the manufacturing date on the battery. The warranty is non-transferable and for the original purchaser. Batteries determined to meet the conditions of this warranty will be replaced free of charge one time. For warranty replacement consideration, fill out the online warranty submission form located on the EarthX website. EarthX's acceptance of any items shipped to EarthX for warranty replacement shall not be deemed an admission that the item(s) are defective. For international warranty returns, the customer will pay the shipping expenses.

Website at <https://earthxbatteries.com/>

Support Email: techsupport@earthxbatteries.com

Phone: 970-674-8884

Regulations and Standards

This battery is designed and tested to the following safety regulations as outlined in:

- FAA Technical Standard Order TSO-C179b

EBBS BACKUP BATTERY

- FAA AC 20-184, Guidance on Testing and Installation of Rechargeable Lithium Battery and Battery Systems on Aircraft
- FAA AC 23.1309-1E, System Safety Analysis and Assessment for Part 23 Airplanes
- RTCA DO-160G, Environmental and Test Procedures for Airborne Equipment
- RTCA DO-254, Design Assurance Guidance for Airborne Electronic Hardware
- RTCA DO-311A, Minimum Operational Performance Standards for Rechargeable Lithium Batteries and Battery Systems
- UN 38.3, – United Nations ST/SG/AC.10/11/Rev.6, Recommendations on the Transport of Dangerous Goods, Manual of Tests and Criteria, Section 38.3, Lithium Metal and Lithium-Ion Batteries.